

RoHS compliant
850 nm multi-mode Transceiver (2 km)
1x9, SC Duplex Connector, 3.3 V
Fast Ethernet



Features

- RoHS compliant
- Industry standard 1×9 footprint
- SC duplex connector
- Single power supply 3.3 V
- Differential LVPECL inputs and outputs
- Compatible with solder and aqueous wash processes

Ordering Information

PART NUMBER	INPUT/OUTPUT	SIGNAL DETECT	VOLTAGE	TEMPERATURE
AC02-A85A2-02	DC/DC	LVPECL	3.3 V	0°C to 70 °C
AC02-A85B2-02	DC/DC	LVPECL	3.3 V	-20°C to 85 °C

Absolute Maximum Ratings

PARAMETER	SYMBOL	MIN	MAX	UNITS	NOTE
Storage Temperature	T_S	-40	85	°C	
Supply Voltage	V_{CC}	-0.5	4.0	V	
Input Voltage	V_{IN}	-0.5	V_{CC}	V	
Output Current	I_o	---	50	mA	
Operating Current	I_{OP}	---	400	mA	
Soldering Temperature	T_{SOLD}	---	260	°C	10 seconds on leads

RoHS compliant
850 nm multi-mode Transceiver (2 km)
1x9, SC Duplex Connector, 3.3 V
Fast Ethernet

Operating Environment

PARAMETER	SYMBOL	MIN	MAX	UNITS	NOTE
Case Operating Temperature (AC02-A85A2-02)	T_C	0	70	°C	
Case Operating Temperature (AC02-A85B2-02)	T_C	-20	85	°C	
Supply Voltage	V_{CC}	3.1	3.5	V	

Transmitter Electro-optical Characteristics

($V_{CC} = 3.1\text{ V to }3.5\text{ V}$, AC02-A85A2-02: $T_C = 0\text{ °C to }70\text{ °C}$, AC02-A85B2-02: $T_A = -20\text{ °C to }85\text{ °C}$)

PARAMETER	SYMBOL	MIN	TYP.	MAX	UNITS	NOTE
Data Rate	B		125		Mb/s	
Output Optical Power 62.5/125 μm fiber	P_{out}	-10	---	-4	dBm	Average
Output Optical Power 50/125 μm fiber		-10	---	-4	dBm	Average
Extinction Ratio	ER	9	---	---	dB	
Center Wavelength	λ_C	830	850	860	nm	
Spectral Width (RMS)	$\Delta\lambda$	---	---	0.85	nm	
Rise/Fall Time (10–90%)	$T_{r,f}$	---	---	2	ns	
Total Jitter	TJ	---	---	1	ns	
Power Supply Current	I_{CC}	---	---	100	mA	Note 1
Transmitter Data Input Voltage-High	$V_{IH} - V_{CC}$	-1.1	---	-0.74	V	Note 2
Transmitter Data Input Voltage-Low	$V_{IL} - V_{CC}$	-2.0	---	-1.58	V	Note 2

Note 1: Not including the terminations.

Note 2: These inputs are compatible with 10K, 10KH and 100K ECL and PECL input.

RoHS compliant
850 nm multi-mode Transceiver (2 km)
1x9, SC Duplex Connector, 3.3 V
Fast Ethernet

Receiver Electro-optical Characteristics

($V_{CC} = 3.1\text{ V to }3.5\text{ V}$, AC02-A85A2-02: $T_C = 0\text{ }^{\circ}\text{C to }70\text{ }^{\circ}\text{C}$, AC02-A85B2-02: $T_A = -20\text{ }^{\circ}\text{C to }85\text{ }^{\circ}\text{C}$)

PARAMETER	SYMBOL	MIN	TYP.	MAX	UNITS	NOTE
Data Rate	B		125		Mb/s	
Optical Input Power-maximum	P_{IN}	0	---	---	dBm	Note 1
Optical Input Power-minimum (Sensitivity)	P_{IN}	---	---	-24	dBm	Note 1
Operating Center Wavelength	λ_C	770	---	860	nm	
Signal Detect-Asserted	P_A	---	---	-24	dBm	Average
Signal Detect-Deasserted	P_D	-45	---	---	dBm	Average
Signal Detect-Hysteresis	$P_A - P_D$	1.0	---	---	dB	
Signal Detect Output voltage-High	$V_{OH} - V_{CC}$	-1.1	---	-0.74	V	Note 2
Signal Detect Output voltage-Low	$V_{OL} - V_{CC}$	-2.0	---	-1.58	V	Note 2
Power Supply Current	I_{CC}	---	---	100	mA	Note 3
Data Output Rise, Fall Time (10-90%)	$T_{r,f}$	---	---	3	ns	
Data Output Voltage-High	$V_{OH} - V_{CC}$	-1.1	---	-0.74	V	Note 2
Data Output Voltage-Low	$V_{OL} - V_{CC}$	-2.0	---	-1.58	V	Note 2

Note 1: The input data is at 125 Mbps, 2^7-1 PRBS data pattern. The receiver is guaranteed to provide output data with Bit Error Rate (BER) better than or equal to 1.0×10^{-10} .

Note 2: These outputs are compatible with 10K, 10KH and 100K ECL and PECL input.

Note 3: The current exclude the output load current.

RoHS compliant

850 nm multi-mode Transceiver (2 km)

1x9, SC Duplex Connector, 3.3 V

Fast Ethernet

Block Diagram of Transceiver

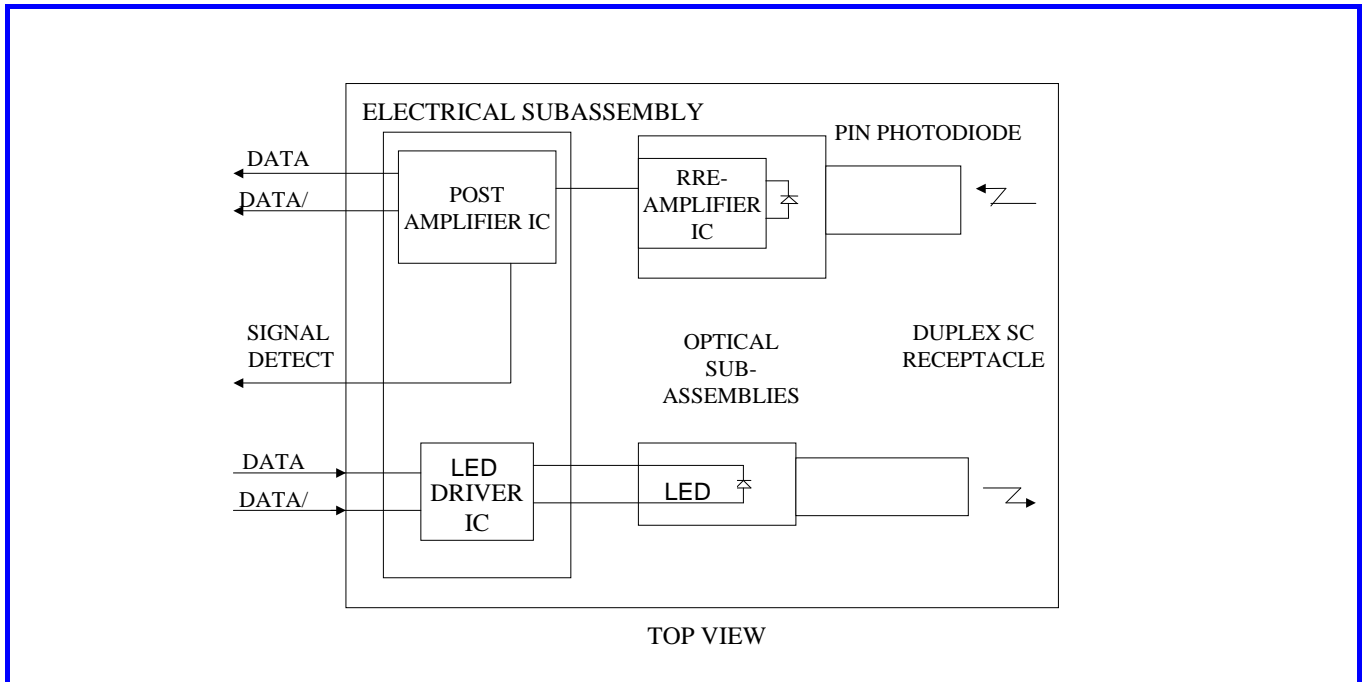

Transmitter Section

The transmitter section consists of a 850 nm VCSEL in an eye safe optical subassembly (OSA) which mates to the fiber cable. The laser OSA is driven by a LD driver IC which converts differential input LVPECL logic signals into an analog laser driving current.

Receiver Section

The receiver utilizes an InGaAs PIN photodiode mounted together with a trans-impedance preamplifier IC in an OSA. This OSA is connected to a circuit providing post-amplification quantization, and optical signal detection.

Receiver Signal Detect

Signal Detect is a basic fiber failure indicator. This is a single-ended LVPECL output. As the input optical power is decreased, Signal Detect will switch from high to low (deassert point) somewhere between sensitivity and the no light input level. As the input optical power is increased from very low levels, Signal Detect will switch back from low to high (assert point). The assert level will be at least 1.0 dB higher than the deassert level.

RoHS compliant
850 nm multi-mode Transceiver (2 km)
1x9, SC Duplex Connector, 3.3 V
Fast Ethernet

Connection Diagram

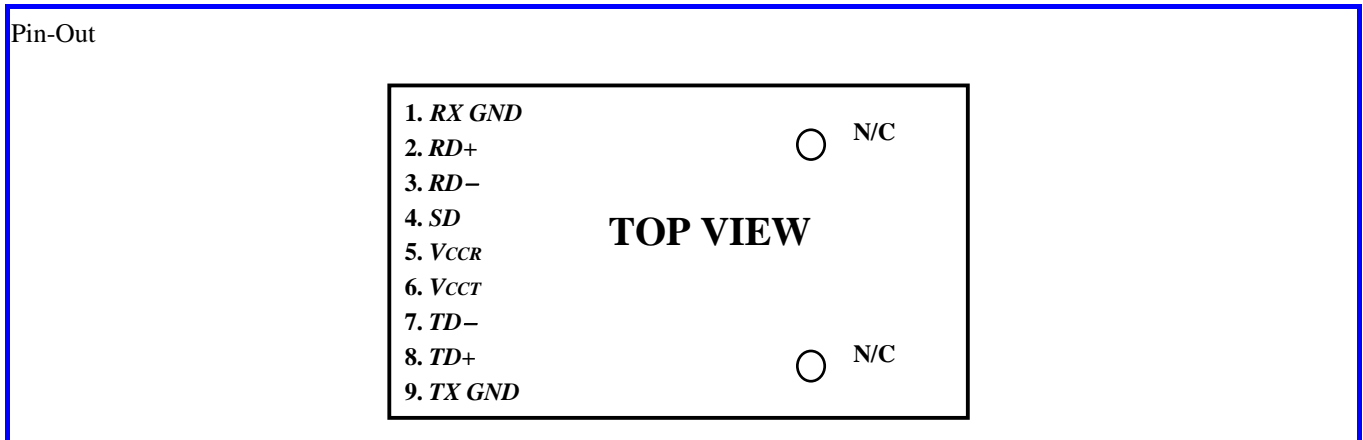

PIN	SYMBOL	DESCRIPTION
1	<i>RX GND</i>	Receiver Signal Ground. Directly connect this pin to the receiver ground plane.
2	<i>RD+</i>	<i>RD+</i> is an open-emitter output circuit. Terminate this high-speed differential LVPECL output with standard LVPECL techniques at the follow-on device input pin. (See recommended circuit schematic)
3	<i>RD-</i>	<i>RD-</i> is an open-emitter output circuit. Terminate this high-speed differential LVPECL output with standard LVPECL techniques at the follow-on device input pin. (See recommended circuit schematic)
4	<i>SD</i>	Signal Detect. Normal optical input levels to the receiver result in a logic “1” output, V_{OH} , asserted. Low input optical levels to the receiver result in a fault condition indicated by a logic “0” output V_{OL} , deasserted. Signal Detect is a single-ended LVPECL output. <i>SD</i> can be terminated with LVPECL techniques via 50 Ω to $V_{CCR} - 2$ V. Alternatively, <i>SD</i> can be loaded with a 180 Ω resistor to <i>RX GND</i> to conserve electrical power with small compromise to signal quality. If Signal Detect output is not used, leave it open-circuited. This Signal Detect output can be used to drive a LVPECL input on an upstream circuit, such as, Signal Detect input or Loss of Signal-bar.
5	V_{CCR}	Receiver Power Supply. Provide +3.3 Vdc via the recommended receiver power supply filter circuit. Locate the power supply filter circuit as close as possible to the V_{CCR} pin.
6	V_{CCT}	Transmitter Power Supply. Provide +3.3 Vdc via the recommended transmitter power supply filter circuit. Locate the power supply filter circuit as close as possible to the V_{CCT} pin.
7	<i>TD-</i>	Transmitter Data In-Bar. Terminate this high-speed differential LVPECL input with standard LVPECL techniques at the transmitter input pin. (See recommended circuit schematic)
8	<i>TD+</i>	Transmitter Data In. Terminate this high-speed differential LVPECL input with standard LVPECL techniques at the transmitter input pin. (See recommended circuit schematic)
9	<i>TX GND</i>	Transmitter Signal Ground. Directly connect this pin to the transmitter signal ground plane. Directly connect this pin to the transmitter ground plane.

RoHS compliant
850 nm multi-mode Transceiver (2 km)
1x9, SC Duplex Connector, 3.3 V
Fast Ethernet

Recommended Circuit Schematic

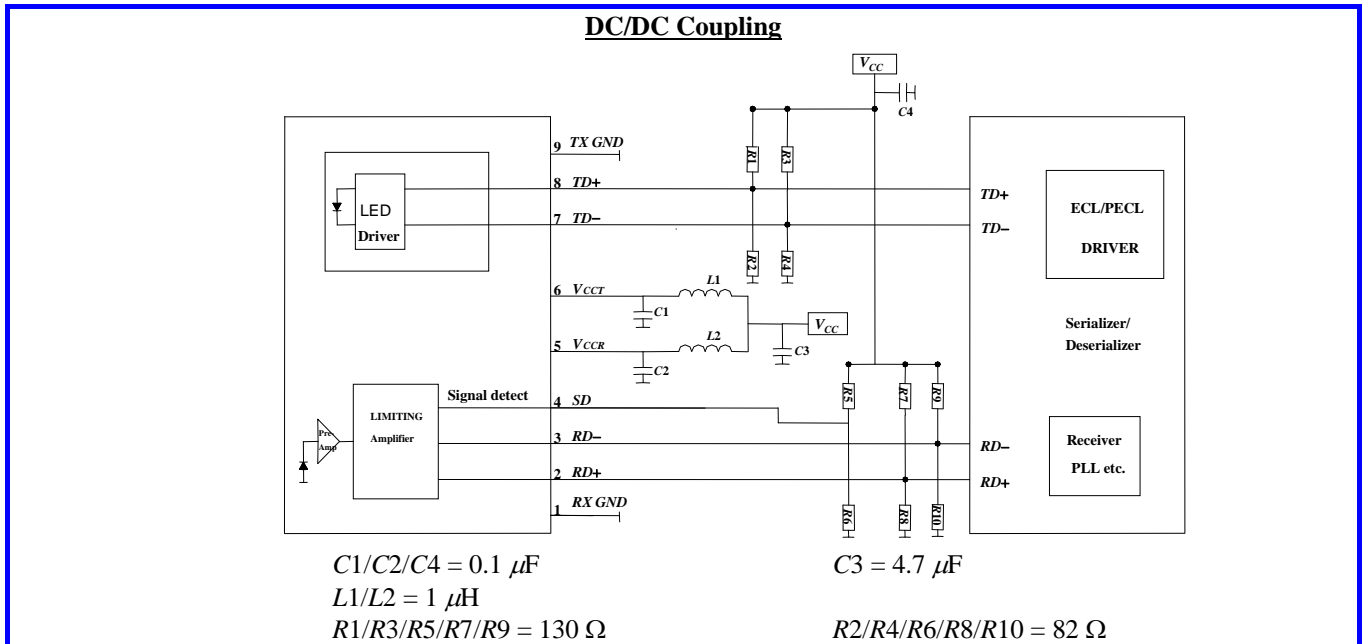

In order to get proper functionality, a recommended circuit is provided in above recommended circuit schematic.

When designing the circuit interface, there are a few fundamental guidelines to follow.

- (1) The differential data lines should be treated as 50 Ω Micro strip or strip line transmission lines. This will help to minimize the parasitic inductance and capacitance effects. Locate termination at the received signal end of the transmission line. The length of these lines should be kept short and of equal length.
- (2) For the high speed signal lines, differential signals should be used, not single-ended signals, and these differential signals need to be loaded symmetrically to prevent unbalanced currents which will cause distortion in the signal.
- (3) Multi layer plane PCB is best for distribution of V_{CC} , returning ground currents, forming transmission lines and shielding, Also, it is important to suppress noise from influencing the fiber-optic transceiver performance, especially the receiver circuit.
- (4) A separate proper power supply filter circuits shown in Figure for the transmitter and receiver sections. These filter circuits suppress V_{CC} noise over a broad frequency range, this prevents receiver sensitivity degradation due to V_{CC} noise.
- (5) Surface-mount components are recommended. Use ceramic bypass capacitors for the 0.1 μF capacitors and a surface-mount coil inductor for 1 μH inductor. Ferrite beads can be used to replace the coil inductors when using quieter V_{CC} supplies, but a coil inductor is recommended over a ferrite bead. All power supply components need to be placed physically next to the V_{CC} pins of the receiver and transmitter.
- (6) Use a good, uniform ground plane with a minimum number of holes to provide a low-inductance ground current return for the power supply currents.

RoHS compliant
850 nm multi-mode Transceiver (2 km)
1x9, SC Duplex Connector, 3.3 V
Fast Ethernet

Recommended Board Layout Hole Pattern

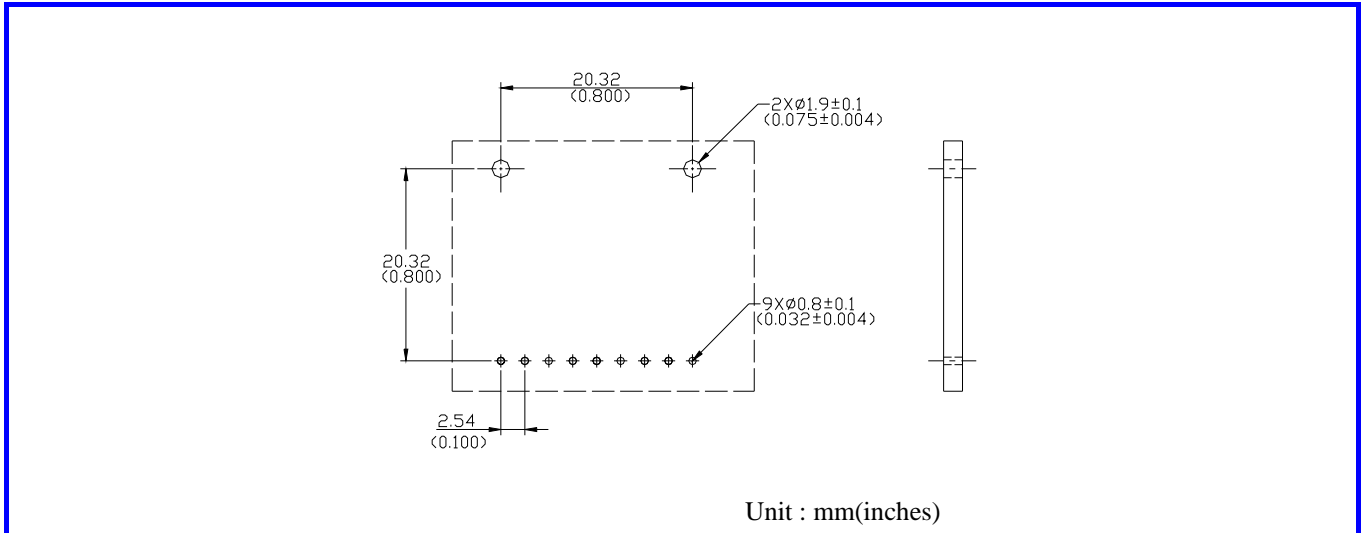

This transceiver is compatible with industry standard wave or hand solder processes. After wash process, all moisture must be completely remove from the module. The transceiver is supplied with a process plug to prevent contamination during wave solder and aqueous rinse as well as during handling, shipping or storage.

Solder fluxes should be water-soluble, organic solder fluxes. Recommended cleaning and degreasing chemicals for these transceivers are alcohol's (methyl, isopropyl, isobutyl), aliphatics (hexane, heptane) and other chemicals, such as soap solution or naphtha. Do not use partially halogenated hydrocarbons for cleaning/degreasing.

RoHS compliant
850 nm multi-mode Transceiver (2 km)
1x9, SC Duplex Connector, 3.3 V
Fast Ethernet

Drawing Dimensions

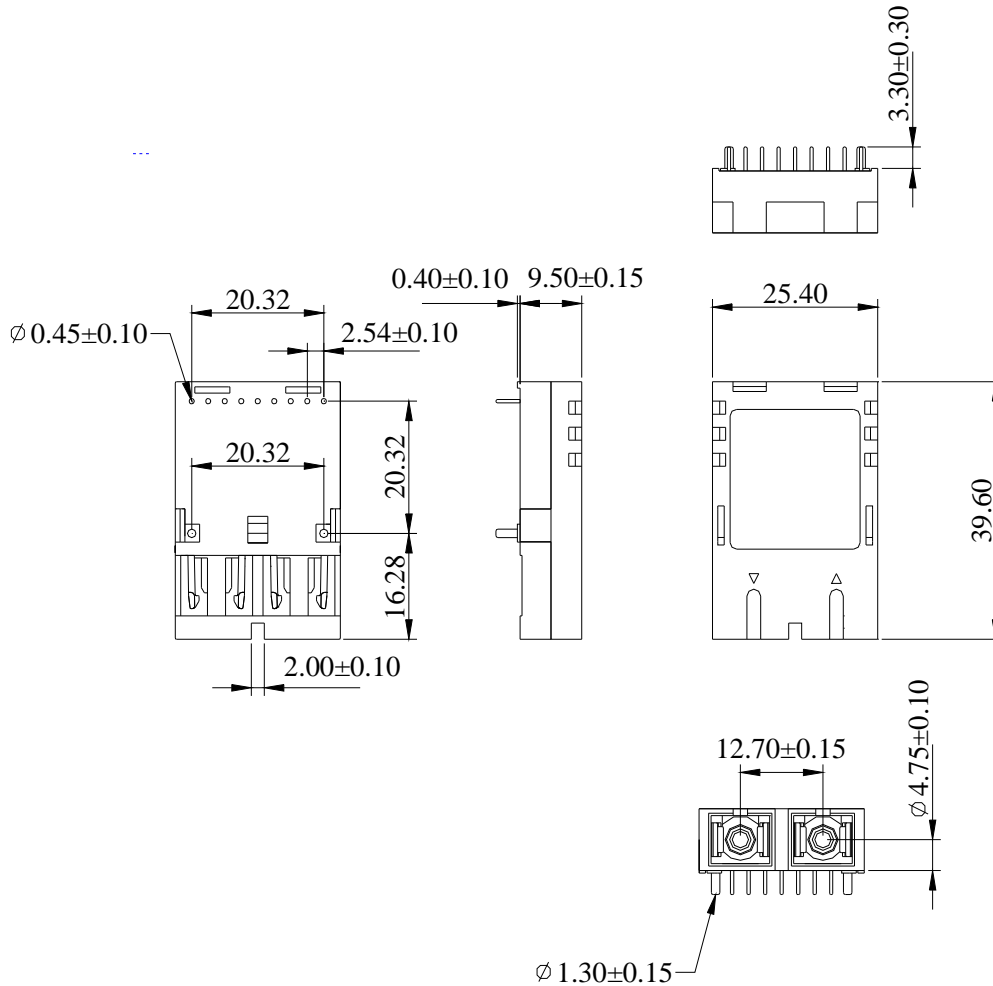

ALL DIMENSIONS ARE ±0.20mm UNLESS OTHERWISE SPECIFIED

Unit : mm

Note : All information contained in this document is subject to change without notice.