

## **AC28-C14L6-20**

### **1.25G 1310/1490nm Compact SFP Transceiver**

#### **PRODUCT FEATURES**

- ◆ 1250Mbps Typical Data Rate and compliant to 1000Base BX20 IEEE802.3ah
- ◆ 1310nm FP laser transmitter  
1490nm DFB laser transmitter
- ◆ PIN photo-detector
- ◆ Up to 20km on 9/125μm SMF
- ◆ Hot-pluggable CSFP footprint
- ◆ LC/UPC type pluggable optical interface
- ◆ Achieve operational compatibility with conventional SFP
- ◆ Metal enclosure, for lower EMI
- ◆ RoHS compliant and lead-free
- ◆ Single +3.3V power supply
- ◆ Support Digital Diagnostic Monitoring interface
- ◆ Compliant with SFF-8472
- ◆ Case operating temperature 0°C to +70°C

#### **APPLICATIONS**

- ◆ Gigabit Ethernet(1000BASE-BX20)
- ◆ Point to Point FTTH Application
- ◆ Switched Backplane Applications
- ◆ Router/Server Interface
- ◆ Switch to Switch Interface
- ◆ Other Optical Links

## PRODUCT DESCRIPTION

AC28-C14L6-20 transceivers are compatible with the Compact Small Form-Factor Pluggable (CSFP) Multi-Source Agreement (MSA) option 2, The transceiver consists of 2-channel Bi-directional Optical Transceiver unit with five sections: the LD driver, the limiting amplifier, the digital diagnostic monitor, the 1310nm FP laser (the 1490nm DFB laser) and the PIN photo-detector .The module data link up to 20KM in 9/125um single mode fiber.

The optical output can be disabled by a TTL logic high-level input of Tx Disable, and the system also can disable the module via I2C. Tx Fault is provided to indicate that degradation of the laser. Loss of signal (LOS) output is provided to indicate the loss of an input optical signal of receiver or the link status with partner. The system can also get the LOS (or Link)/Disable/Fault information via I2C register access.

Conventional SFP will function when plugged into a C-SFP socket, at the same time no damage to C-SFP and host board if C-SFP module is plugged into a conventional SFP socket

## Ordering information

Product part Number	Data Rate (Gbps)	Media	Wavelength (nm)	Transmission Distance(km)	Temperature Range ( Tcase ) ( °C )	
AC28-C14L6-20	1.25	Single mode fiber	1310/1490(1490/1310)	20	0~70	commercial

## I . Pin Descriptions

Pin#	Name	Function	Notes
1	VEE	Transceiver Ground	VEE may be internally connected within the SFP module
2	TX FAULT	Transmitter Fault Indication	TX Fault is an open collector/drain output, which should be pulled up with a 4.7K–10K resistor on the host board. Note 1 for more information
3	TX1_ Disable	Transmitter Disable of Ch A	Module channel A disables function
4	MOD-DEF2	Two-wires interface Data	2 wire serial ID interface, SDA
5	MOD-DEF1	Two-wires interface Clock	2 wire serial ID interface, SCL
6	TD2-	Inverted Transmit Data Input of Ch B	These are the differential transmitter puts. They are AC-coupled, differential lines with 100 differential termination inside the module. The AC coupling is done inside the module and is thus not required on the host board
7	TD2+	Transmit Data Input of Ch B	
8	LOS1	Loss of Signal of Ch A	Loss of Signal detected function. Note 2 for more information.
9	RD2+	Received Data Output of Ch B	These are the differential receiver outputs. They are AC coupled 100 differential lines which should be terminated with 100(differential) at the user SERDES. The AC coupling is done inside the module and is thus not required on the host board.
10	RD2-	Inverted Received Data Output of Ch B	
11	VEE	Transceiver Ground	VEE may be internally connected within the SFP module.
12	RD1-	Inverted Received Data Output of Ch A	These are the differential receiver outputs. They are AC coupled 100 differential lines which should be terminated with 100(differential) at the user SERDES. The AC coupling is done inside the module and is thus not required on the host board.
13	RD1+	Received Data Output of Ch A	
14	LOS2	Loss of Signal of CH B	Loss of Signal detected function. Note 2 for more information.
15	VCCR	Receiver Power	3.3V± 5%. Note 3 for more information
16	VCCT	Transmitter Power	3.3V± 5%. Note 3 for more information
17	TX2_ Disable	Transmitter Disable of Ch B	Module channel B disables function
18	TD1+	Transmit Data Input of Ch A	These are the differential transmitter puts. They are AC-coupled, differential lines with 100 differential termination inside the module. The AC coupling is done inside the module and is thus not required on the host board
19	TD1-	Inverted Transmit Data Input of Ch A	
20	VEE	Transceiver Ground	VEE may be internally connected within the SFP module.

Note 1: When high, output indicates a laser fault of some kind either in Channel A or Channel B. The Host shall read Channel A/B for details: TX Fault from channel A if bit 2 is set in [A2H:110]; TX Fault from channel B if bit 2 is set in [B2H: 110]. Low indicates normal operation. In the low state, the output will be pulled to < 0.8V.

Note 2: When high, this output indicates the received optical power is below the worst-case receiver sensitivity (as defined by the standard in use). Low indicates normal operation. In the low state, the output will be pulled to < 0.4V.

Note 3: VccT VccR are the power supplies. They are defined as 3.3V ±5% at the SFP connector pin. Maximum supply current is 400Ma@3.3V. Vcc may be internally connected within the SFP transceiver module.

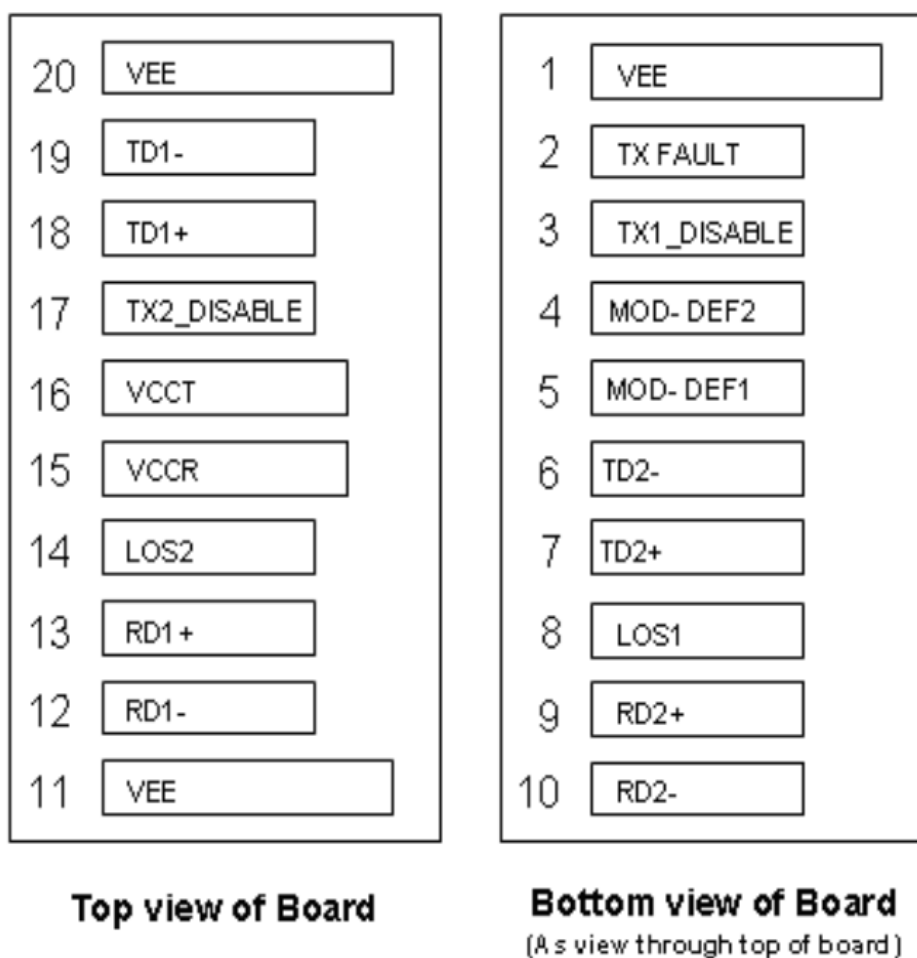

**Figure 2: Pin out of Connector Block on Host Board**

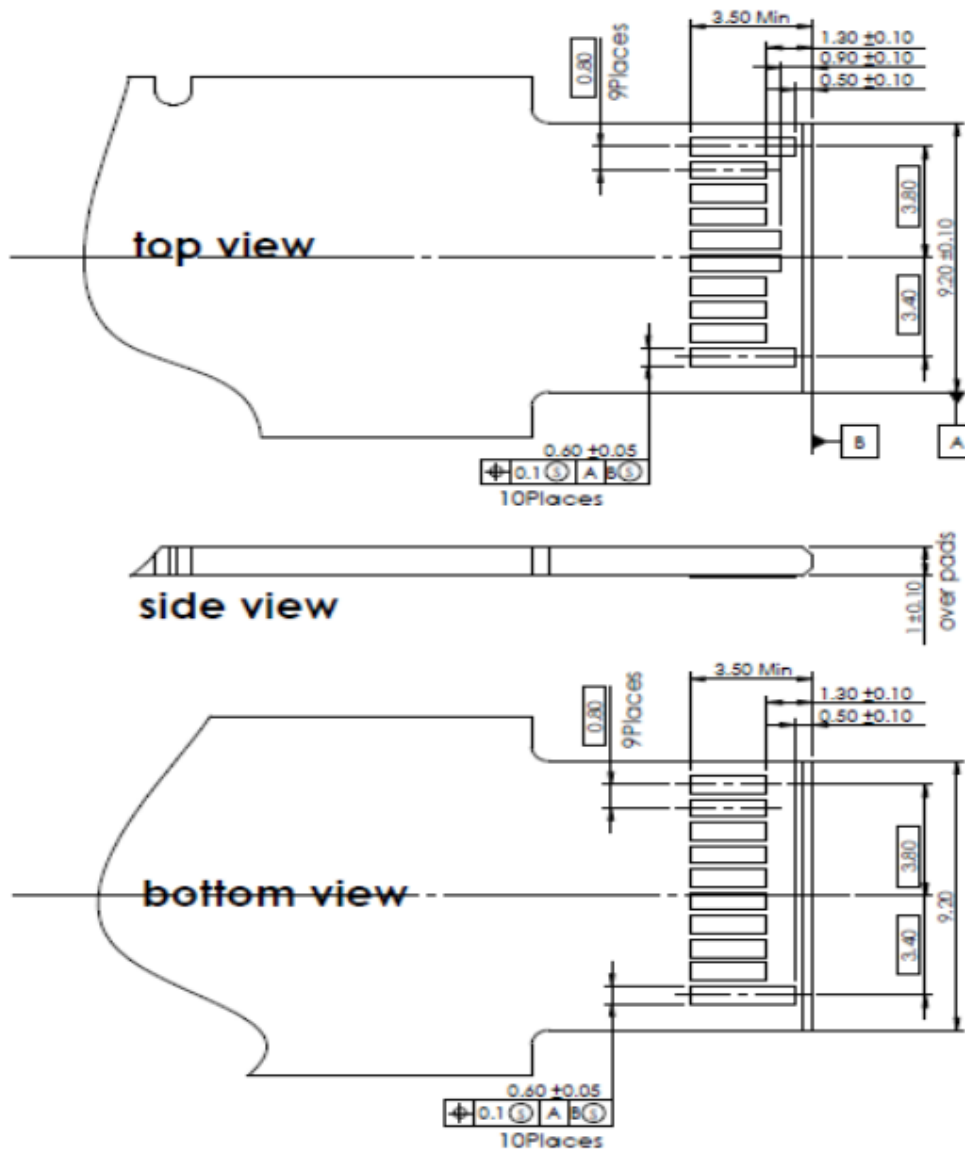

## II. Absolute Maximum Ratings

Parameter	Symbol	Min.	Typ.	Max.	Unit	Note
Storage Temperature	Ts	-40		85	°C	
Storage Ambient Humidity	HA	5		95	%	
Power Supply Voltage	Vcc	-0.5		4	V	
Signal Input Voltage		-0.3		Vcc+0.3	V	
Receiver Damage Threshold		3			dBm	

## III. Recommended Operating Conditions

Parameter	Symbol	Min.	Typ.	Max.	Unit	Note
Case Operating Temperature	T <sub>case</sub>	0		70	°C	AC28-C14L6-20
Ambient Humidity	H <sub>A</sub>	5		70	%	Non-condensing
Power Supply Voltage	V <sub>cc</sub>	3.13	3.3	3.47	V	
Power Supply Current	I <sub>cc</sub>			450	mA	
Power Supply Noise Rejection				100	mVp-p	100Hz to 1MHz
Data Rate			1.25/1.25		Gbps	TX Rate/RX Rate
Transmission Distance				20	KM	
Coupled Fiber	Single mode fiber					9/125um SMF

## IV. Specification of Transmitter

Parameter	Symbol	Min.	Typ.	Max.	Unit	Note
Average Output Power	P <sub>OUT</sub>	-9		-3	dBm	
Extinction Ratio	ER	8			dB	
Center Wavelength	$\lambda_c$	1270	1310	1360	nm	
		1470	1490	1510		
Spectrum Width (RMS)	$\sigma$			3.5	nm	FP Laser (TX:1310nm)
Side Mode Suppression Ratio	SMSR	30			dB	DFB Laser (TX:1490nm)
Spectrum Bandwidth(-20dB)	$\sigma$			1	nm	
Transmitter OFF Output Power	P <sub>Off</sub>			-45	dBm	
Differential Line Input Impedance	R <sub>IN</sub>	90	100	110	Ohm	
Jitter P-P	t <sub>J</sub>			128	ps	Note (1)
Output Eye Mask	Compliant with IEEE802.3 ah (class 1 laser safety)					Note (2)

Note (1): Measure at 2<sup>7</sup>-1 NRZ PRBS pattern

Note (2): Transmitter eye mask definition, and eye mask diagram with at least 10% margin.

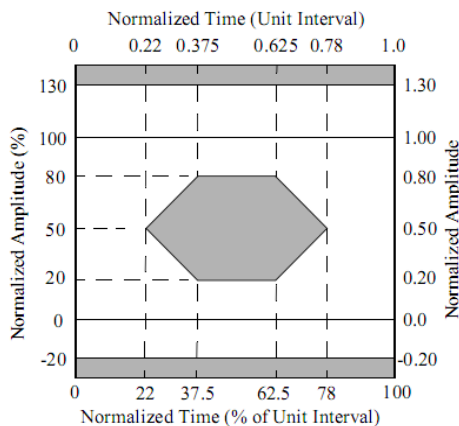

## V. Specification of Receiver

Parameter	Symbol	Min.	Typ.	Max.	Unit	Note
Input Optical Wavelength	$\lambda_{IN}$	1470	1490	1510	nm	
		1270	1310	1360		
Receiver Sensitivity	$P_{IN}$			-19	dBm	Note (1)
Input Saturation Power (Overload)	$P_{SAT}$	-3			dBm	
Los Of Signal Assert	$P_A$	-38			dBm	
Los Of Signal De-assert	$P_D$			-22	dBm	Note (2)
LOS Hysteresis	$P_A-P_D$	0.5	2	6	dB	

Note (1): Measured with Light source 1490nm(1310nm), ER=8dB; BER  $\leq 10^{-12}$  @PRBS=2<sup>7</sup>-1 NRZ

Note (2): When LOS de-asserted, the RX data+/- output is High-level (fixed)

## VI. Electrical Interface Characteristics

Parameter	Symbol	Min.	Typ.	Max.	Unit	Note
<b>Transmitter</b>						
Total Supply Current	$I_{CC}$			A	mA	Note (1)
Transmitter Disable Input-High	$V_{DISH}$	2		$V_{CC}+0.3$	V	
Transmitter Disable Input-Low	$V_{DISL}$	0		0.8	V	
Transmitter Fault Input-High	$V_{DISL}$	2		$V_{CC}+0.3$	V	
Transmitter Fault Input-Low	$V_{TXFH}$	0		0.8	V	
<b>Receiver</b>						
Total Supply Current	$I_{CC}$			B	mA	Note (1)
LOSS Output Voltage-High	$V_{LOSH}$	2		$V_{CC}+0.3$	V	LVTTTL
LOSS Output Voltage-Low	$V_{LOSL}$	0		0.8	V	

Note (1): A (TX) + B (RX) = 450mA (Not include termination circuit)

## VII. Digital Diagnostic Functions

AC28-C14L6-20 transceivers support the 2-wire serial communication protocol as defined in the CSFP MSA. It is very closely related to the E2PROM defined in the GBIC standard, with the same electrical specifications.

The standard CSFP serial ID provides access to identification information that describes the transceiver's capabilities, standard interfaces, manufacturer, and other information.

Additionally, XGIGA CSFP transceivers provide a unique enhanced digital diagnostic monitoring interface, which allows real-time access to device operating parameters such as transceiver temperature, laser bias current, transmitted optical power, received optical power and transceiver supply voltage. It also defines a sophisticated system of alarm and warning flags, which alerts end-users when particular operating parameters are outside of a factory set normal range.

The CSFP MSA defines a 256-byte memory map in E2PROM that is accessible over a 2-wire serial interface at the 8 bit address 1010000X (A0h) or 1011000X(B0h). The digital diagnostic monitoring interface makes use of the 8 bit address 1010001X (A2h) or 1011001X(B2h), so the originally defined serial ID memory map remains unchanged. The digital diagnostic memory is defined as follow:

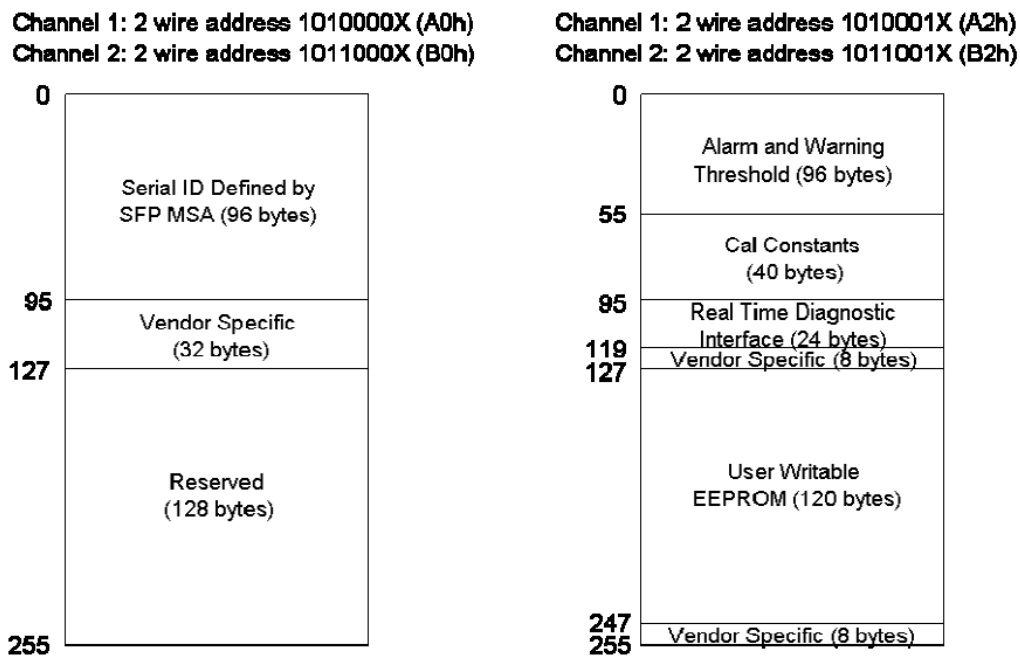

Figure 29 Memory map of 2ch Compact SFP (option 2)



The operating and diagnostics information is monitored and reported by a Digital Diagnostics Transceiver Controller (DDTC) inside the transceiver, which is accessed through a 2-wire serial interface. When the serial protocol is activated, the serial clock signal (SCL, Mod Def 1) is generated by the host. The positive edge clocks data into the SFP transceiver into those segments of the E2PROM that are not write-protected. The negative edge clocks data from the SFP transceiver. The serial data signal (SDA, Mod Def 2) is bi-directional for serial data transfer. The host uses SDA in conjunction with SCL to mark the start and end of serial protocol activation. The memories are organized as a series of 8-bit data words that can be addressed individually or sequentially.

Digital diagnostics for the AC28-C14L6-20 are internally calibrated by default.

## VIII. Recommend Circuit Diagram

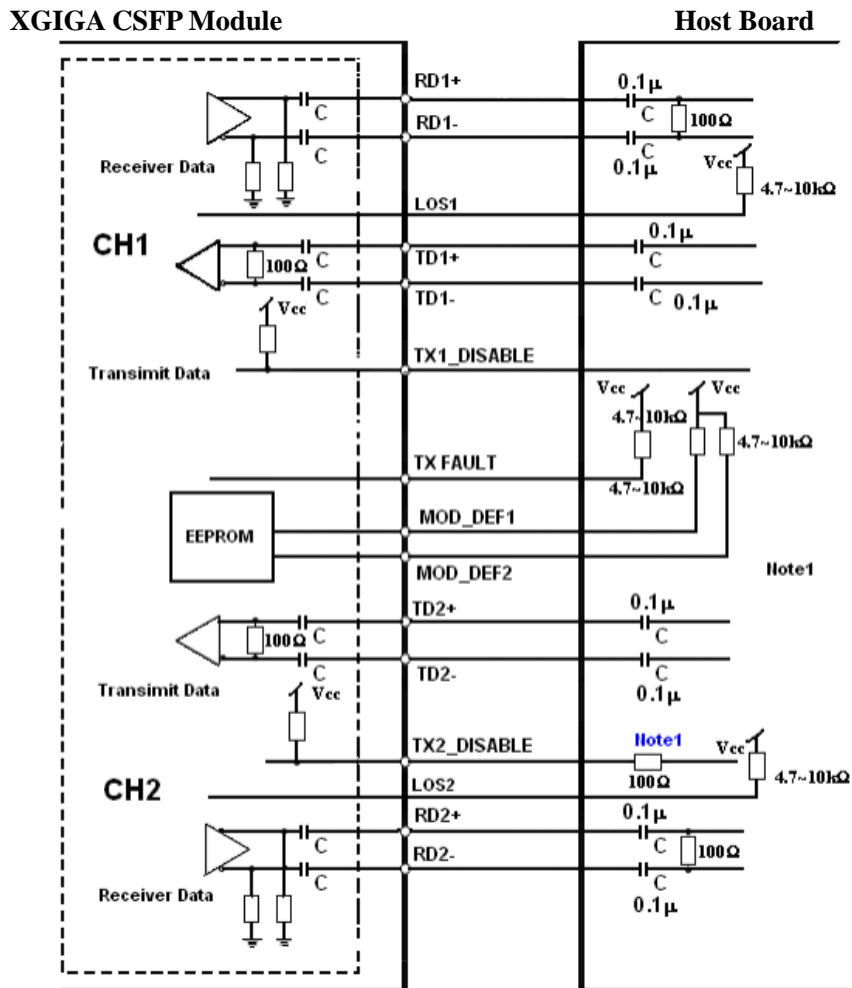

**Note1 :** Recommendation 100Ω series resistance on host board.

## IX. Mechanical Specifications (Unit: mm)

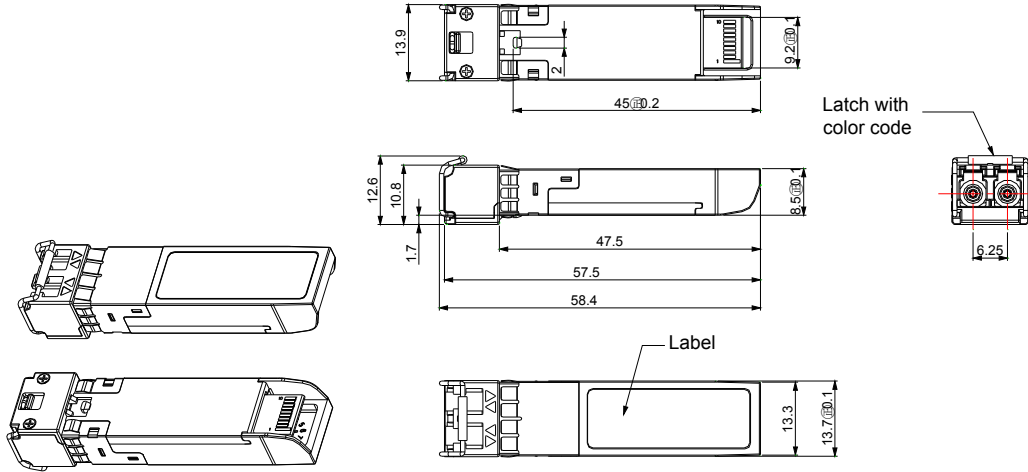

## X. Regulatory Compliance

Feature	Reference	Performance
Electrostatic discharge (ESD)	IEC/EN 61000-4-2	Compatible with standards
Electromagnetic Interference (EMI)	FCC Part 15 Class B EN 55022 Class B (CISPR 22A)	Compatible with standards
ROHS	2002/95/EC	Compatible with standards
EMC	EN61000-3	Compatible with standards

## Appendix A. Document Revision

Version No.	Date	Description
1.0	2011-10-25	Preliminary datasheet