

RoHS Compliant

TX-1310/RX-1490 , Bi-directional , Point to Multipoint (ONU)

2×5 Receptacle SC Connector, 3.3 V

GE-PON Transceiver , 1000BASE-PX10, 10km



Features

- Compliant with IEEE 802.3ah 1000BASE-PX10
- Industry standard 2×5 footprint
- SC connector
- Single power supply 3.3 V
- Differential LVPECL inputs and outputs
- Transmitter burst mode and Receiver continuous mode
- Compatible with solder and aqueous wash processes
- Class 1 laser product complies with EN 60825-1

Ordering Information

PART NUMBER	TX	RX	IN/OUT	SD	Burst Control	RX 1550nm Input	TEMPERATURE	LD TYPE
AC36-C19L2-10-R	1310 nm	1490 nm	AC/AC	LVTTL	LVTTL (Enable: Logic "1")	°C to 70°C	Blocked	FP

RoHS Compliant
 TX-1310/RX-1490 , Bi-directional , Point to Multipoint (ONU)
 2×5 Receptacle SC Connector, 3.3 V
 GE-PON Transceiver , 1000BASE-PX10, 10km

Absolute Maximum Ratings

PARAMETER	SYMBOL	MIN	MAX	UNITS	NOTE
Storage Temperature	T_S	-40	85	°C	
Case Ambient Temperature	T_C	-40	85	°C	
Supply Voltage	V_{CC}	0	4.0	V	
Soldering Temperature	T_{SOLD}	---	260	°C	10 seconds on leads
Optical Input Power (Peak, 1550nm)	P_{1650}		+10	dBm	
Optical Input Power (Peak, 1650nm)	P_{1650}		+10	dBm	
Optical Input Power (average, 1490nm)	P_{in}		+2	dBm	

Operating Environment

PARAMETER	SYMBOL	MIN	MAX	UNITS	NOTE
Case Operating Temperature	T_C	0	70	°C	
Supply Voltage	V_{CC}	3.135	3.465	V	
Supply Current(B.O.L)	$I_{TX} + I_{RX}$	---	350	mA	
Supply Current(E.O.L)	$I_{TX} + I_{RX}$	---	400	mA	
Humidity (without dew)	RH	10	95	% RH	
Signaling Speed		1.25 -100ppm	1.25 +100ppm	Gbps	

RoHS Compliant
TX-1310/RX-1490 , Bi-directional , Point to Multipoint (ONU)
2×5 Receptacle SC Connector, 3.3 V
GE-PON Transceiver , 1000BASE-PX10, 10km

Transmitter Electro-optical Characteristics

$V_{CC} = 3.135 \text{ V to } 3.465 \text{ V}, T_C = 0^\circ \text{C to } 70^\circ \text{C}$

PARAMETER	SYMBOL	MIN	TYP.	MAX	UNITS	NOTE
Output Optical Power (BOL) 9/125 μm fiber (Average)	P_{out}	0		+4	dBm	
Output Optical Power (EOL) 9/125 μm fiber (Average)		-1		+4	dBm	
Extinction Ratio	ER	9	---	---	dB	
Center Wavelength	λ_C	1260	1310	1360	nm	
Spectral Width (RMS)	$\Delta\lambda$		Table 1		nm	
Rise/Fall Time (20–80%)	$T_{r,f}$	---	---	260	ps	
RIN _{15OMA}	RIN			-113	dB/Hz	
Output Eye		Compliant with IEEE802.3z, IEEE802.3ah				
Average Launched power of OFF transmitter	P_{OFF}			-45	dBm	
TX Burst off /Disable Assert Time	T_{on}			32	ns	
TX Burst off/Disable Negate Time	T_{off}			32	ns	
Transmitter reflectance				-10	dB	$\lambda=1310\text{nm}$
TX Burst off /Disable Voltage-High	V_{IH}	2.0	---	VCC	V	LVTTL
TX Burst off /Disable Voltage-Low	V_{IL}	0	---	0.8	V	LVTTL
Data Input Voltage-Differential	V_{Diff}	0.3	---	2.0	V	

RoHS Compliant

TX-1310/RX-1490 , Bi-directional , Point to Multipoint (ONU)

2×5 Receptacle SC Connector, 3.3 V

GE-PON Transceiver , 1000BASE-PX10, 10km

Table 1

Center Wavelength (nm)	Maximum RMS spectral width (nm)
1260	2.09
1270	2.52
1280	3.13
1286	3.50
1290	
1297	
1329	
1340	
1343	
1350	3.06
1360	2.58

Table 2: Optical output operation

Item	Input & Condition		Output
	DATA	TX _{Dis}	Optical output *1
1	Normal data	Enable	ON
2	Logical High Continuation		Other
3	Logical Low Continuation		Other
4	Same Level		Other
5	X	Disable	OFF

X=Do not care(include Same level)

*1: ON=Optical output, OFF=Less than -45dBm, Other= Less than +7.5dBm(peak)

RoHS Compliant

TX-1310/RX-1490 , Bi-directional , Point to Multipoint (ONU)

2×5 Receptacle SC Connector, 3.3 V

GE-PON Transceiver , 1000BASE-PX10, 10km

Receiver Electro-optical Characteristics

$V_{CC} = 3.135\text{ V to }3.465\text{ V}$, $T_C = 0^\circ\text{C to }70^\circ\text{C}$

PARAMETER	SYMBOL	MIN	TYP.	MAX	UNITS	NOTE
Optical Input Power-maximum	P_{IN}	-3	---	---	dBm	BER < 10^{-12}
Optical Input Power-minimum (Sensitivity)	P_{IN}	---	---	-26.5	dBm	Note1
Operating Center Wavelength	λ_C	1480	1490	1500	nm	
Optical isolation (1260 ~1360nm)	ISO	---	---	-45	dB	
Optical isolation (1550 ~ 1560nm)	ISO	---	---	-25	dB	
Receiver reflectance (1480 to 1500nm)		---	---	-12	dB	Note2
Receiver reflectance (1550 to 1560nm)		---	---	-20	dB	Note3
Signal Detect-Asserted	P_A	---	---	-27	dBm	
Signal Detect-Deasserted	P_D	-44	---	---	dBm	
Signal Detect-Hysteresis	$P_A - P_D$	0.5	---	---	dB	
Signal Detect Output voltage-High	V_{OH}	2.4	---	V_{CC}	V	LVTTL
Signal Detect Output voltage-Low	V_{OL}	0	---	0.4	V	LVTTL
Differential Output Voltage	V_{DIFF}	1.2	---	1.9	V	
S/X Endurance	1550 to 1560 nm			-18	dB	Note 4
	1625 to 1655nm			4	dB	Note 5

Note1: With BER better than or equal to 1.0×10^{-12} , measured in the center of eye opening with 2^7-1 NRZ PRBS, and Extinction Ratio=9.0dB.

Note2: Measured with 1490nm

Note3: Measured with 1550nm

Note4: When the asynchronous 1.25Gbps 0/1 of 1550 to 1560nm wavelength 18dB higher than downstream optical power(average) is received during communication with OLT, 1×10^{-12} or less bit error rate satisfied.

Note5: When the asynchronous CW light (peak) of 1625 to 1655nm wavelength 4dB lower than downstream optical power(average) is received during communication with OLT, 1×10^{-12} or less bit error rate satisfied.

RoHS Compliant

TX-1310/RX-1490 , Bi-directional , Point to Multipoint (ONU)

2×5 Receptacle SC Connector, 3.3 V

GE-PON Transceiver , 1000BASE-PX10, 10km

Block Diagram of Transceiver

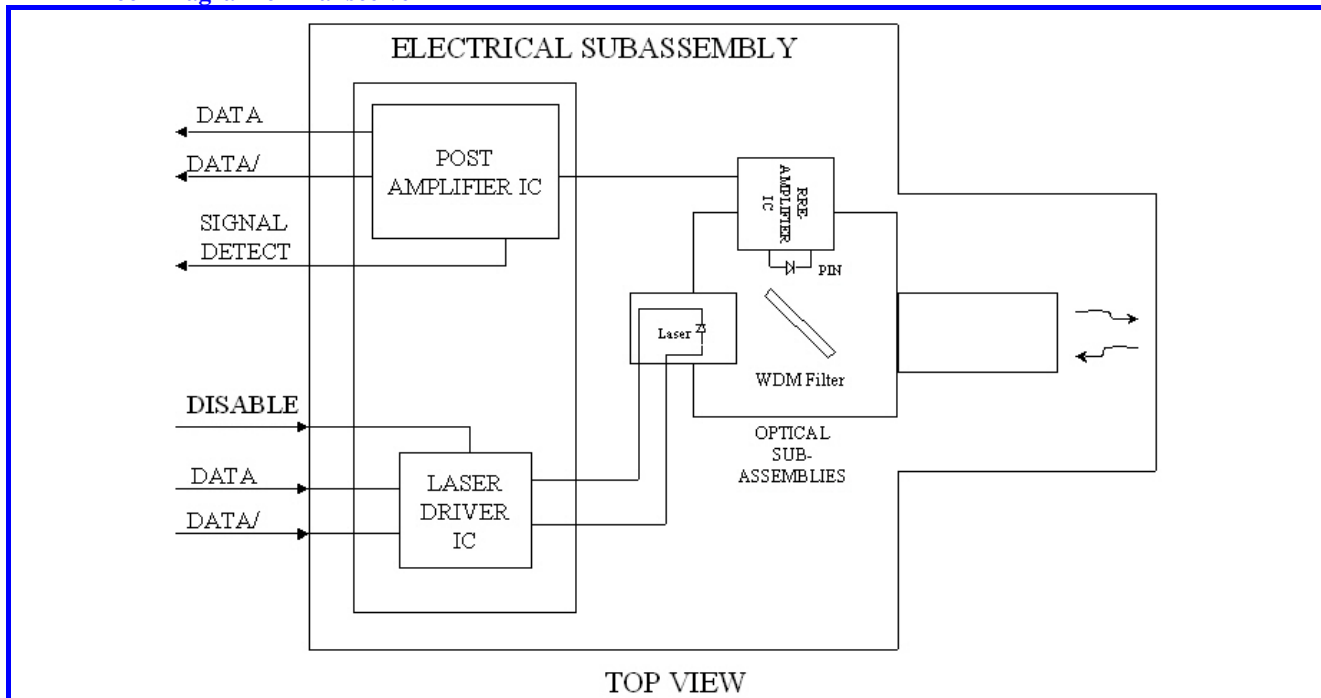

Transmitter and Receiver Optical Sub-assembly Section

A 1310 nm InGaAsP laser and an InGaAs PIN photodiode integrate with an WDM filter to form a bi-directional single fiber optical subassembly (OSA). The laser of OSA is driven by a LD driver IC which converts differential input LVPECL logic signals into an analog laser driving current. And, The photodiode of OSA is connected to a circuit providing post-amplification quantization, and optical signal detection.

Transmitter Disable/Burst off

Transmitter Disable/Burst off is a LVTTTL control pin. To disable the module, connect this pin to +3.3 V LVTTTL logic high "0". While, to enable module connect to LVTTTL logic low "1".

Receiver Signal Detect

Signal Detect is a basic fiber failure indicator. This is a single-ended LVTTTL output. As the input optical power is decreased, Signal Detect will switch from high to low (deassert point) somewhere between sensitivity and the no light input level. As the input optical power is increased from very low levels, Signal Detect will switch back from low to high (assert point).

RoHS Compliant

TX-1310/RX-1490 , Bi-directional , Point to Multipoint (ONU)

2×5 Receptacle SC Connector, 3.3 V

GE-PON Transceiver , 1000BASE-PX10, 10km

Connection Diagram

Pin-Out

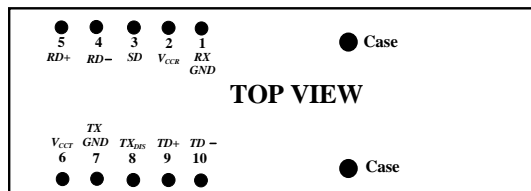

PIN	SYMBOL	DESCRIPTION
1	<i>RX GND</i>	Receiver Signal Ground, Directly connect this pin to the receiver ground plane.
2	<i>VCCR</i>	Receiver Power Supply Provide +3.3 Vdc via the recommended receiver power supply filter circuit. Locate the power supply filter circuit as close as possible to the <i>VCCR</i> pin.
3	<i>SD</i>	Signal Detect. Normal optical input levels to the receiver result in a logic “1” output, <i>V_{OH}</i> , asserted. Low input optical levels to the receiver result in a fault condition indicated by a logic “0” output <i>V_{OL}</i> , de-asserted. Signal Detect is a single-ended LVTTTL output. If Signal Detect output is not used, leave it open-circuited.
4	<i>RD-</i>	Receiver data output. AC coupled output
5	<i>RD+</i>	Receiver data output. AC coupled output
6	<i>VCCR</i>	Transmitter Power Supply Provide +3.3 Vdc via the recommended transmitter power supply filter circuit. Locate the power supply filter circuit as close as possible to the <i>VCCR</i> pin.
7	<i>TX GND</i>	Transmitter Signal Ground Directly connect this pin to the transmitter signal ground plane. Directly connect this pin to the transmitter ground plane.
8	<i>TX_{off}</i>	Transmitter Enable/Burst on Connect this pin to LVTTTL logic high “1” to enable transmitter. To disable module connect to LVTTTL logic low “0”.
9	<i>TD+</i>	Transmitter Data In Input internally biased and AC coupled
10	<i>TD-</i>	Transmitter Data In-Bar Input internally biased and AC coupled

RoHS Compliant

TX-1310/RX-1490 , Bi-directional , Point to Multipoint (ONU)

2x5 Receptacle SC Connector, 3.3 V

GE-PON Transceiver , 1000BASE-PX10, 10km

Recommended Circuit Schematic

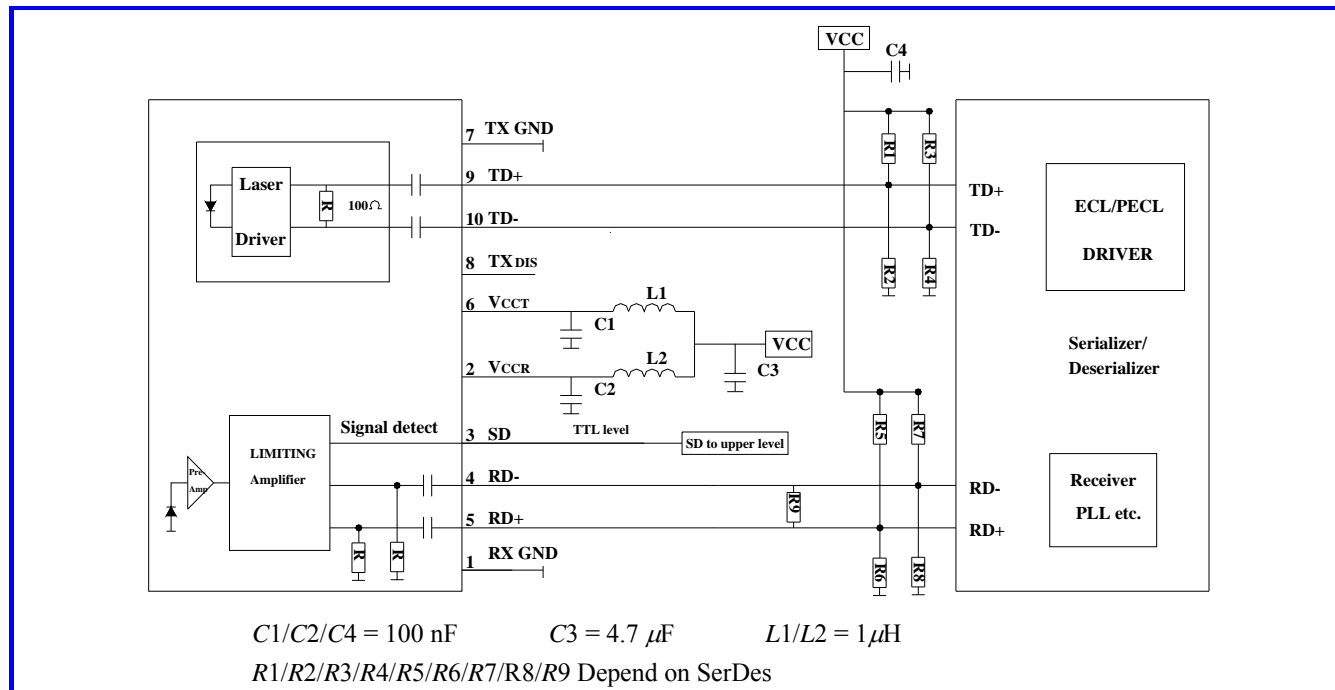

In order to get proper functionality, a recommended circuit is provided in above recommended circuit schematic. When designing the circuit interface, there are a few fundamental guidelines to follow.

- (1) The differential data lines should be treated as 50 Ω Micro strip or strip line transmission lines. This will help to minimize the parasitic inductance and capacitance effects. Locate termination at the received signal end of the transmission line. The length of these lines should be kept short and of equal length.
- (2) For the high speed signal lines, differential signals should be used, not single-ended signals, and these differential signals need to be loaded symmetrically to prevent unbalanced currents which will cause distortion in the signal.
- (3) Multi layer plane PCB is best for distribution of V_{CC} , returning ground currents, forming transmission lines and shielding. Also, it is important to suppress noise from influencing the fiber-optic transceiver performance, especially the receiver circuit.
- (4) A separate proper power supply filter circuits shown in Figure for the transmitter and receiver sections. These filter circuits suppress V_{CC} noise over a broad frequency range, this prevents receiver sensitivity degradation due to V_{CC} noise.
- (5) Surface-mount components are recommended. Use ceramic bypass capacitors for the 0.1 μF capacitors and a surface-mount coil inductor for 1 μH inductor. Ferrite beads can be used to replace the coil inductors when using quieter V_{CC} supplies, but a coil inductor is recommended over a ferrite bead. All power supply components need to be placed physically next to the V_{CC} pins of the receiver and transmitter.
- (6) Use a good, uniform ground plane with a minimum number of holes to provide a low-inductance ground current return for the power supply currents.

RoHS Compliant

TX-1310/RX-1490 , Bi-directional , Point to Multipoint (ONU)

2x5 Receptacle SC Connector, 3.3 V

GE-PON Transceiver , 1000BASE-PX10, 10km

Recommended Board Layout Hole Pattern

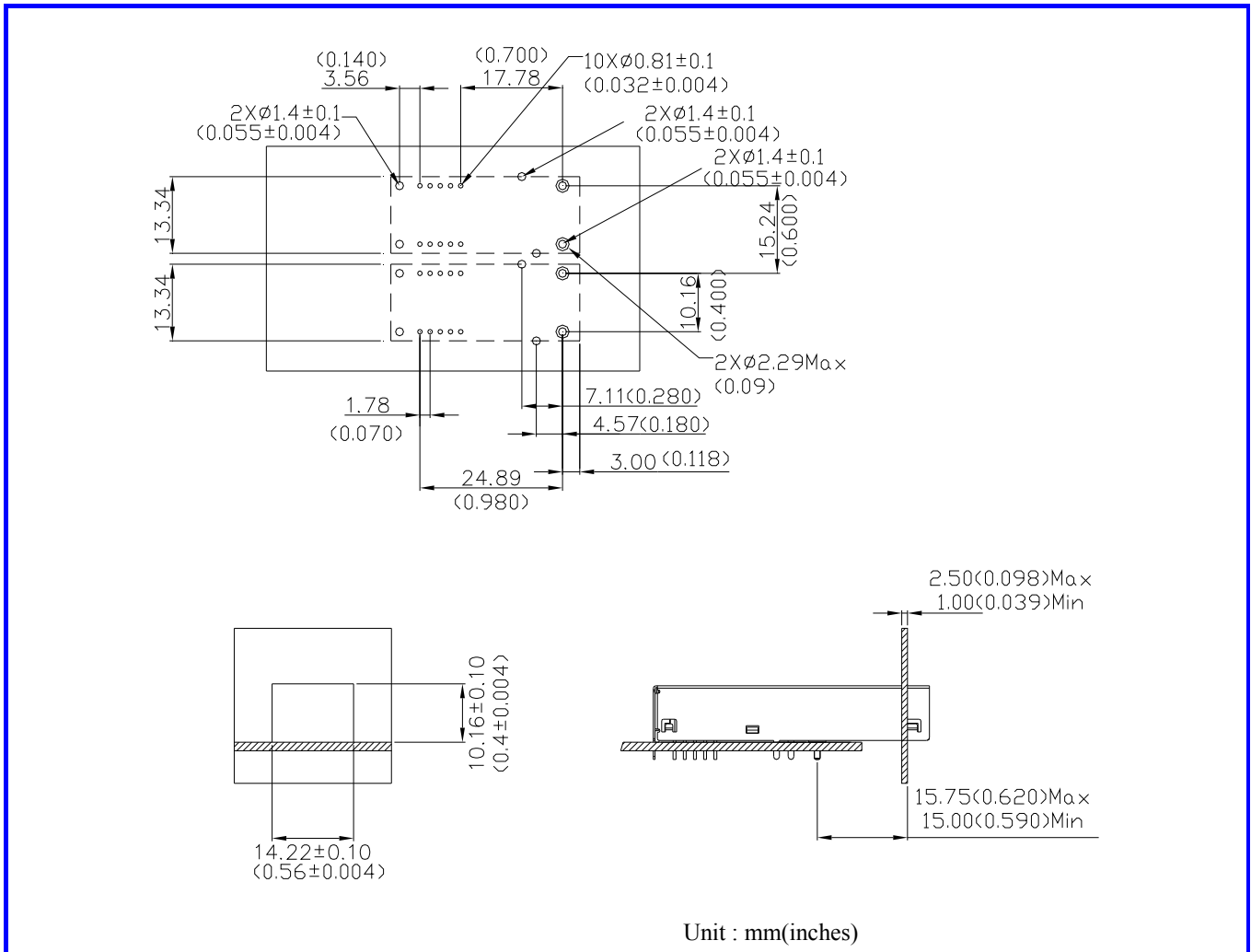

This transceiver is compatible with industry standard wave or hand solder processes. After wash process, all moisture must be completely remove from the module. The transceiver is supplied with a process plug to prevent contamination during wave solder and aqueous rinse as well as during handling, shipping or storage.

Solder fluxes should be water-soluble, organic solder fluxes. Recommended cleaning and degreasing chemicals for these transceivers are alcohol's (methyl, isopropyl, isobutyl), aliphatics (hexane, heptane) and other chemicals, such as soap solution or naphtha. Do not use partially halogenated hydrocarbons for cleaning/degreasing.

RoHS Compliant

TX-1310/RX-1490 , Bi-directional , Point to Multipoint (ONU)

2x5 Receptacle SC Connector, 3.3 V

GE-PON Transceiver , 1000BASE-PX10, 10km

Drawing Dimensions

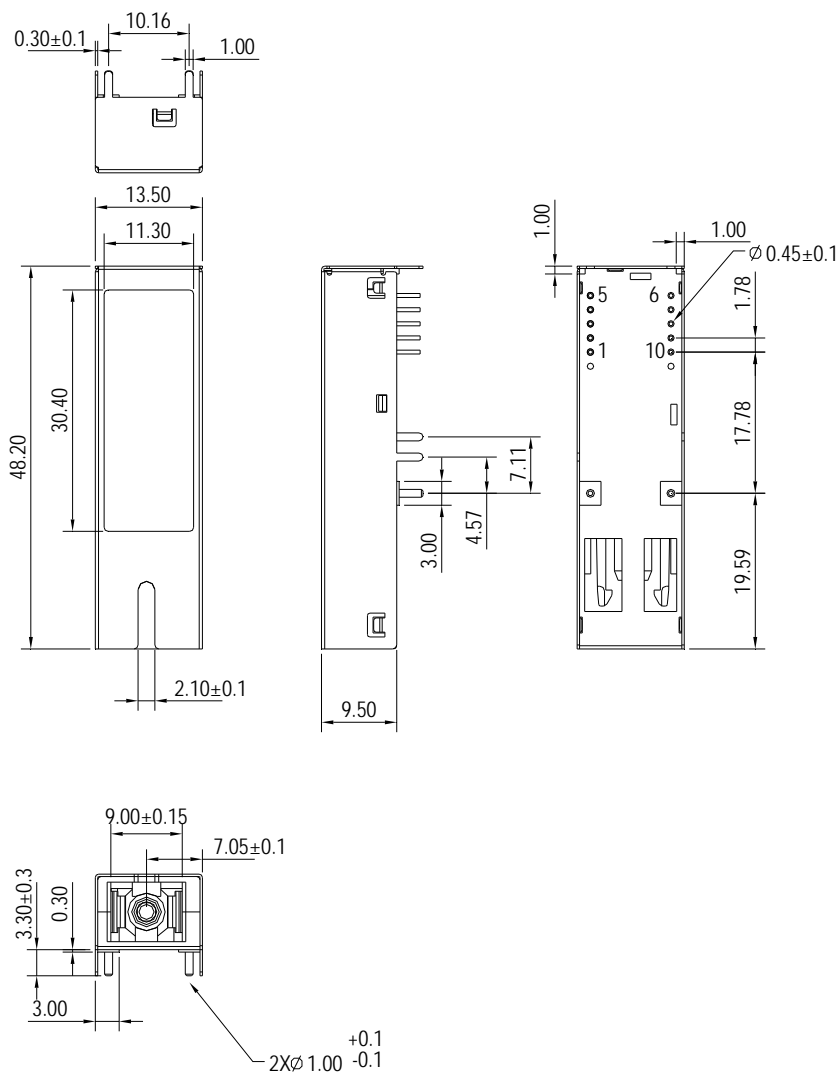

ALLDIMENSIONS ARE±0.20mm UNLESS OTHERWISE SPECIFIED
Unit : mm

RoHS Compliant

TX-1310/RX-1490 , Bi-directional , Point to Multipoint (ONU)

2×5 Receptacle SC Connector, 3.3 V

GE-PON Transceiver , 1000BASE-PX10, 10km

Eye Safety Mark

The AC36 series Single mode transceiver is a class 1 laser product. It complies with EN 60825-1 and FDA 21 CFR 1040.10 and 1040.11. In order to meet laser safety requirements the transceiver shall be operated within the Absolute Maximum Ratings.

Caution

All adjustments have been done at the factory before the shipment of the devices. No maintenance and user serviceable part is required. Tampering with and modifying the performance of the device will result in voided product warranty.

Required Mark

Class 1 Laser Product
Complies with
21 CFR 1040.10 and 1040.11

Note : All information contained in this document is subject to change without notice.