

1550 nm Single-mode XFP Transceiver up to 80km link length

10GBASE-ZW/ZR Ethernet

SONET OC-192/SDH STM-64 ITU-T G.959.1 P1L1-2D2

SONET OC-192/SDH STM-64 with ITU-T G.709

Preliminary

## Features

- Compliant with IEEE802.3ae 10GBASE-ZW/ZR Ethernet
- Compliant with SONET OC-192/SDH STM-64 ITU-T G.959.1 P1L1-2D2
- Compliant with SONET OC-192/SDH STM-64 with ITU-T G.709
- Compliant with 80km 10G Fiber Channel
- Compliant with XFP MSA INF-8077i
- Differential LVPECL inputs and CML outputs
- TTL signal detect indicator
- Hot Pluggable
- Class 1 laser product complies with EN 60825-1

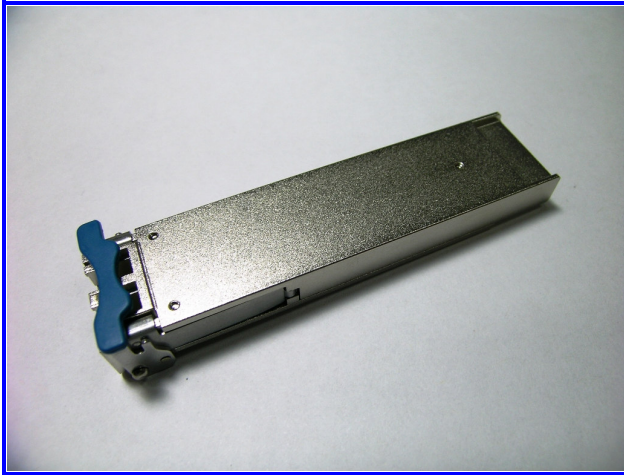

## Ordering Information

PART NUMBER	INPUT/OUTPUT	SIGNAL DETECT	VOLTAGE	TEMPERATURE
XFP-ZR	AC/AC	TTL	3.3V	0°C to 70°C

## Absolute Maximum Ratings

PARAMETER	SYMBOL	MIN	MAX	UNITS	NOTE
Storage Temperature	$T_s$	-40	85	°C	
Supply Voltage	$V_{cc3}$	-0.5	4.0	V	
	$V_{cc5}$	-0.5	6.0	V	
	$V_{cc-5}$	-6	0.5	V	

**1550 nm Single-mode XFP Transceiver up to 80km link length**
**10GBASE-ZW/ZR Ethernet**
**SONET OC-192/SDH STM-64 ITU-T G.959.1 P1L1-2D2**
**SONET OC-192/SDH STM-64 with ITU-T G.709**
**Preliminary**
**Recommended Operating Conditions**

PARAMETER	SYMBOL	MIN	MAX	UNITS	NOTE
Case operating Temperature	$T_c$	0	70	°C	
Supply Voltage	$V_{cc3}$	3.1	3.5	V	
Supply Current	$I_{cc3}$	---	1000	mA	
Supply Voltage	$V_{cc5}$	4.5	5.5	V	
Supply Current	$I_{cc5}$	---	200	mA	
Supply Voltage	$V_{cc-5}$	-4.5	-5.5	V	
Supply Current	$I_{cc-5}$	---	200	mA	

**Transmitter Electro-optical Characteristics**
 $V_{cc3} = 3.1 \text{ V to } 3.5 \text{ V}, V_{cc5} = 4.5 \text{ V to } 5.5 \text{ V}, V_{cc-5} = -5.5 \text{ V to } -4.5 \text{ V}, T_c = 0^\circ \text{C to } 70^\circ \text{C}$ 

PARAMETER	SYMBOL	MIN	TYP.	MAX	UNITS	NOTE
Operating Data Rate			9.95/ 11.09		Gbps	
Input Reference Clock Rate			No Required			
Output power	$P_{OUT}$	0		4	dBm	
Optical Modulation Amplitude(OMA)	$P_{OMA}$	-2.4	---	---	dBm	
Extinction Ratio	$ER$	9			dB	
Center Wavelength	$\lambda_c$	1530		1565	nm	
Sidemode Suppression ratio	$SSR_{min}$	30				dB
Relative Intensity Noise	$RIN$	---	---	-130	dB/Hz	
Output Eye			Compliant with IEEE802.3ae			
Differential Input Voltage	$V_{DIFF}$	0.12	---	1.0	V	
Transmit Fault Output-Low	$TX\_FAULT_L$	0.0	---	0.5	V	
Transmit Fault Output-High	$TX\_FAULT_H$	2.4	---	$V_{CC}$	V	
TX_DISABLE Assert Time	$t_{off}$	---	---	10	$\mu s$	

1550 nm Single-mode XFP Transceiver up to 80km link length

10GBASE-ZW/ZR Ethernet

SONET OC-192/SDH STM-64 ITU-T G.959.1 P1L1-2D2

SONET OC-192/SDH STM-64 with ITU-T G.709

Preliminary

TX_DISABLE Negate Time	$t_{on}$	---	---	2	ms
Time to initialize	$t_{init}$	---	---	300	ms
Interrupt assert delay	$\overline{\text{Interrupt}}_{on}$	---	---	200	ms
Interrupt negate delay	$\overline{\text{Interrupt}}_{off}$	---	---	500	$\mu s$
P_Down/RST assert delay	P_Down/RST_on			100	$\mu s$
Mod_NR assert delay	Mod_nr_on			1	ms
Mod_NR negate delay	Mod_nr_off			1	ms
P-Down reset time		10			$\mu s$
RX_LOS assert delay	$t_{loss\_on}$			100	$\mu s$
RX_LOS negate delay	$t_{loss\_off}$			100	$\mu s$

**1550 nm Single-mode XFP Transceiver up to 80km link length**
**10GBASE-ZW/ZR Ethernet**
**SONET OC-192/SDH STM-64 ITU-T G.959.1 P1L1-2D2**
**SONET OC-192/SDH STM-64 with ITU-T G.709**
**Preliminary**
**Receiver Electro-optical Characteristics**
 $V_{cc3} = 3.1 \text{ V to } 3.5 \text{ V}$ ,  $V_{cc5} = 4.5 \text{ V to } 5.5 \text{ V}$ ,  $V_{cc-5} = -5.5 \text{ V to } -4.5 \text{ V}$ ,  $T_C = 0^\circ \text{C to } 70^\circ \text{C}$ 

PARAMETER	SYMBOL	MIN	TYP.	MAX	UNITS	NOTE
Receiver Sensitivity		-23		-7	dBm	BER < 10 <sup>-12</sup>
Receiver Sensitivity (OMA)	$P_{IN}$	---	---	-22.1	dBm	BER < 10 <sup>-12</sup>
Operating Center Wavelength	$\lambda_C$	1270	---	1600	nm	
Receiver Reflectance	$R_{rx}$	27	---	---	dB	
Dispersion Penalty				3	dB	40 km@11.1Gbps
Loss of Signal-Asserted	$P_A$	---	---	-30	dBm	
Loss of Signal-Deasserted	$P_D$	-22	---	---	dBm	
Differential Output Voltage	$V_{DIFF}$	0.6		0.8	V	
TTL Input High Voltage		2		V <sub>cc</sub>	V	
TTL Input Low Voltage		0		0.8	V	
TTL Output High Voltage		2.4	---	V <sub>cc</sub>	V	
TTL Output Low Voltage		0	---	0.4	V	
Receiver Loss of Signal Assert Time (off to on)	$t_{A,RX\_LOS}$	---	---	100	$\mu\text{s}$	
Receiver Loss of Signal Assert Time (on to off)	$t_{D,RX\_LOS}$	---	---	100	$\mu\text{s}$	

1550 nm Single-mode XFP Transceiver up to 80km link length

10GBASE-ZW/ZR Ethernet

SONET OC-192/SDH STM-64 ITU-T G.959.1 P1L1-2D2

SONET OC-192/SDH STM-64 with ITU-T G.709

Preliminary

## Block Diagram of Transceiver

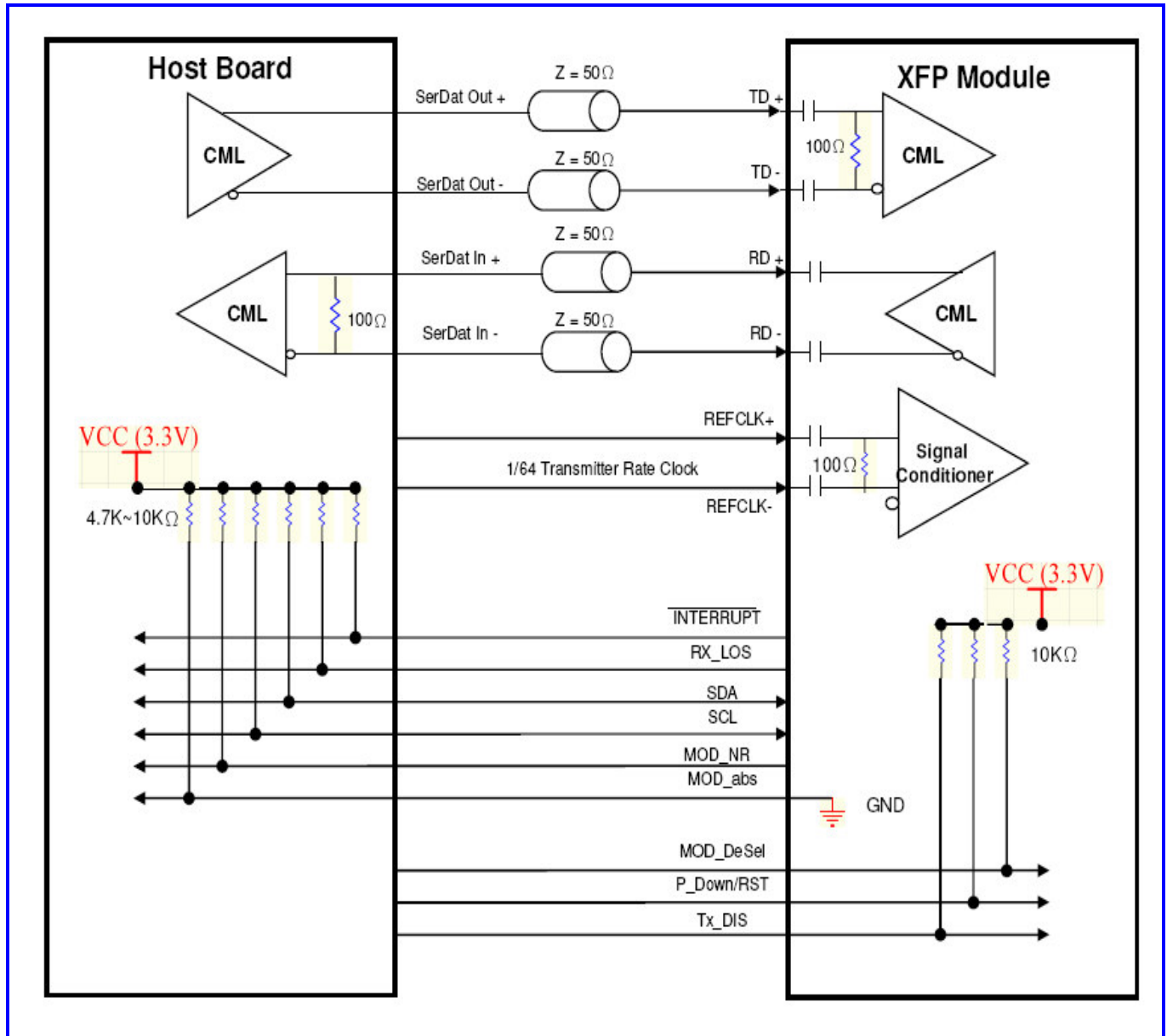

**1550 nm Single-mode XFP Transceiver up to 80km link length****10GBASE-ZW/ZR Ethernet****SONET OC-192/SDH STM-64 ITU-T G.959.1 P1L1-2D2****SONET OC-192/SDH STM-64 with ITU-T G.709****Preliminary****MOD\_NR**

The Mod\_NR is an output pin that when High, indicates that the module has detected a condition that renders transmitter and or receiver data invalid, shall consist of logical OR of the following signals:

- Transmit Signal Conditioner Loss of Lock
- Transmitter Laser Fault
- Receiver Signal Conditioner Loss of Lock

**MOD\_DESEL**

The Mod\_DeSel is an input pin. When held Low by the host, the module responds to 2-wire serial communication commands. The Mod\_DeSel allows the use of multiple XFP modules on a single 2-wire interface bus.

When the Mod\_DeSel pin is “High”, the module shall not respond to or acknowledge any 2-wire interface communication from the host.

**INTERRUPT**

Interrupt is an output pin. When “Low”, indicates possible module operational fault or a status critical to the host system.

**TX\_DIS**

TX\_DIS is an input pin. When TX\_DIS is asserted High, the XFP module transmitter output must be turned off.

**MOD\_ABS**

Mod\_ABS is pulled up to Host\_Vcc on the host board and grounded in the XFP module. Mod\_ABS is then asserted “High” when the XFP module is physically absent from a host slot.

**RX\_LOS**

The RX\_LOS when High indicates insufficient optical power for reliable signal reception.

**P\_Down/RST**

This is a multifunction pin for module Power Down and Reset. The P\_Down/RST pin must be pulled up to VCC3 in the XFP module.

**POWER DOWN FUNCTION**

The P\_Down pin, when held High by the host, places the module in the standby (Low Power) mode with a maximum power dissipation of 1.5W. This protects hosts which are not capable of cooling higher power modules which may be accidentally inserted.

1550 nm Single-mode XFP Transceiver up to 80km link length

10GBASE-ZW/ZR Ethernet

SONET OC-192/SDH STM-64 ITU-T G.959.1 P1L1-2D2

SONET OC-192/SDH STM-64 with ITU-T G.709

Preliminary

## Dimensions

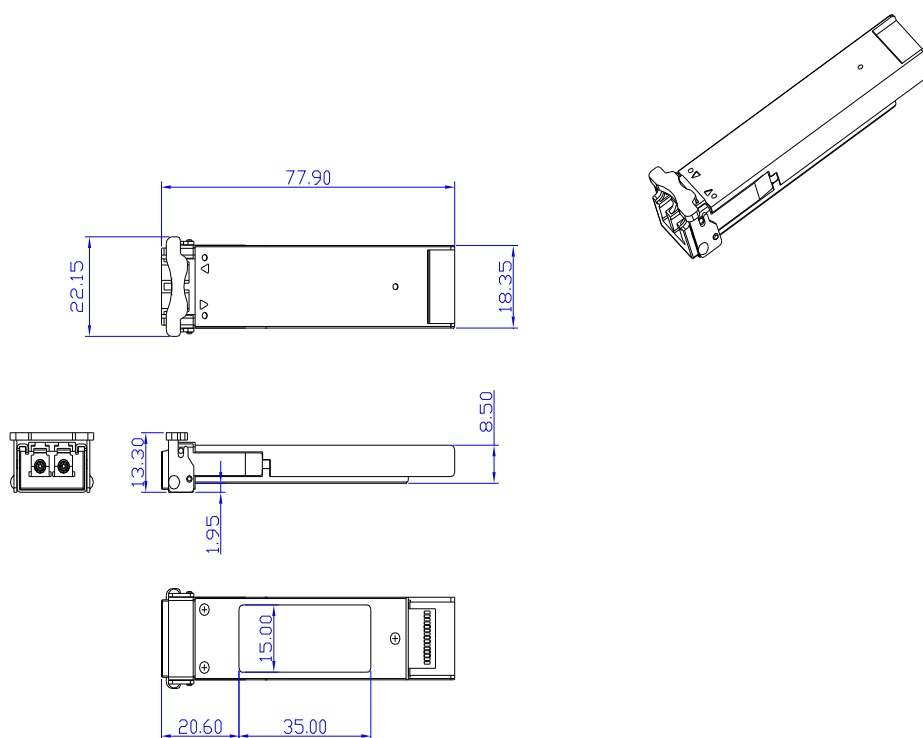

**DIMENSIONS ARE IN MILLIMETERS**

**ALL DIMENSIONS ARE  $\pm 0.2\text{mm}$  UNLESS OTHERWISE SPECIFIED**

1550 nm Single-mode XFP Transceiver up to 80km link length

10GBASE-ZW/ZR Ethernet

SONET OC-192/SDH STM-64 ITU-T G.959.1 P1L1-2D2

SONET OC-192/SDH STM-64 with ITU-T G.709

Preliminary

## Pin Assignment

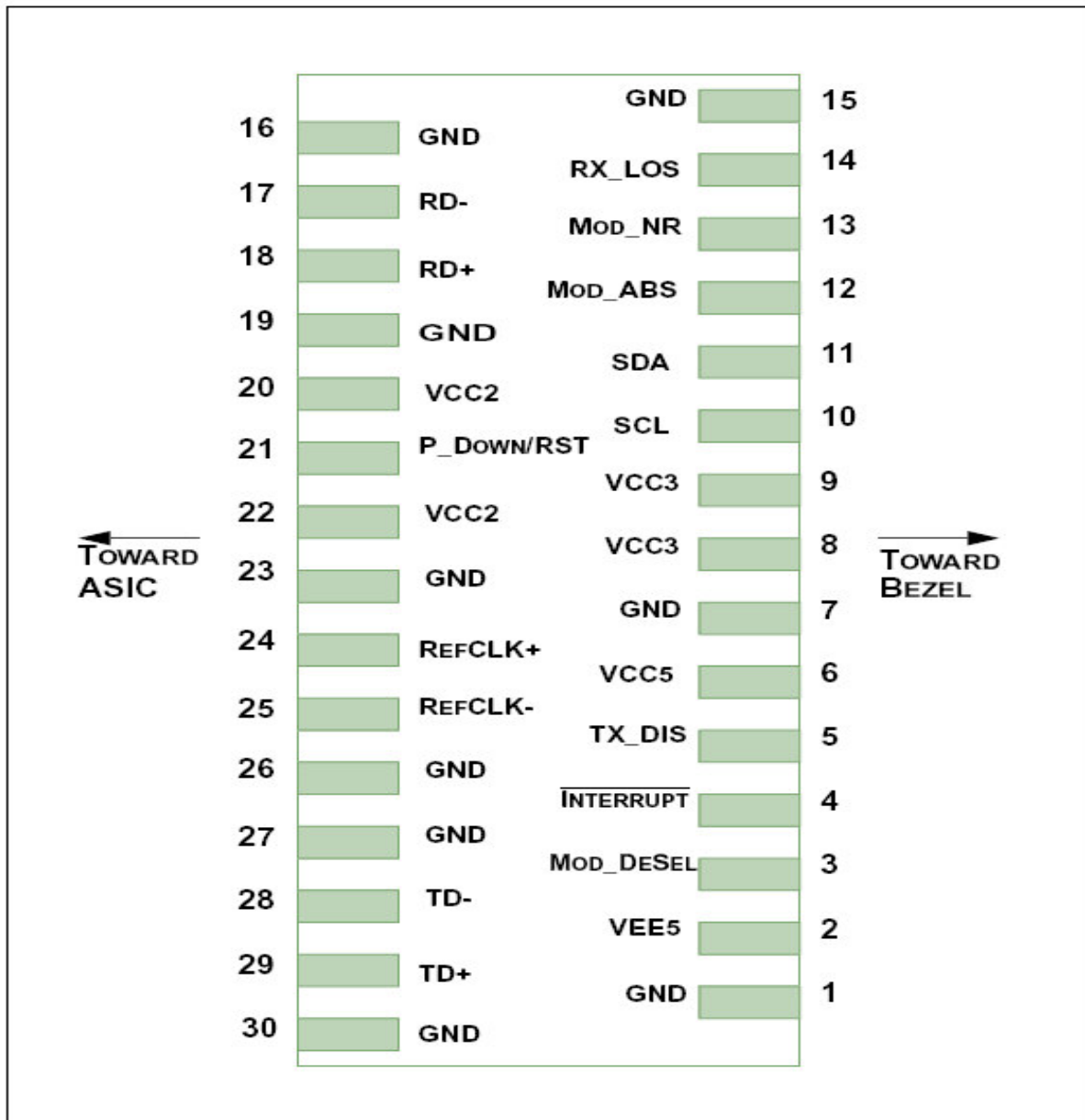



1550 nm Single-mode XFP Transceiver up to 80km link length

10GBASE-ZW/ZR Ethernet

SONET OC-192/SDH STM-64 ITU-T G.959.1 P1L1-2D2

SONET OC-192/SDH STM-64 with ITU-T G.709

Preliminary

Pin	Logic	Symbol	Name/Description	Note
1		GND	Module Ground	1
2		VEE5	Optional -5.2V Power Supply	
3	LVTTL-I	Mod_DeSel	Module De-select; When held low allows module to respond to 2-wire serial interface	
4	LVTTL-O	Interrupt	Interrupt; Indicates presence of an important condition which can be read over the 2-wire serial interface	2
5	LVTTL-I	TX_DIS	Transmitter Disable; Turns off transmitter laser output	
6		VCC5	+5V Power Supply	
7		GND	Module Ground	1
8		VCC3	+3.3V Power Supply	
9		VCC3	+3.3V Power Supply	
10	LVTTL-I/O	SCL	2-Wire Serial Interface Clock	2
11	LVTTL-I/O	SDA	2-Wire Serial Interface Data Line	2
12	LVTTL-O	Mod_Abs	Indicates Module is not present. Grounded in the Module	2
13	LVTTL-O	Mod_NR	Module Not Ready; Indicating Module Operational Fault	2
14	LVTTL-O	RX_LOS	Receiver Loss Of Signal Indicator	2
15		GND	Module Ground	1
16		GND	Module Ground	1
17	CML-O	RD-	Receiver Inverted Data Output	
18	CML-O	RD+	Receiver Non-Inverted Data Output	
19		GND	Module Ground	1
20		VCC2	+1.8V Power Supply	3
21	LVTTL-I	P_Down/RST	Power down; When high, requires the module to limit power consumption to 1.5W or below. 2-Wire serial interface must be functional in the low power mode. Reset; The falling edge initiates a complete reset of the module including the 2-wire serial interface, equivalent to a power cycle.	
22		VCC2	+1.8V Power Supply	3
23		GND	Module Ground	1
24	PECL-I	RefCLK+	Reference Clock Non-Inverted Input, AC coupled on the host board	
25	PECL-I	RefCLK-	Reference Clock Inverted Input, AC coupled on the host board	
26		GND	Module Ground	1
27		GND	Module Ground	1
28	CML-I	TD-	Transmitter Inverted Data Input	
29	CML-I	TD+	Transmitter Non-Inverted Data Input	
30		GND	Module Ground	1

1. Module ground pins Gnd are isolated from the module case and chassis ground within the module.
2. Shall be pulled up with 4.7K-10Kohms to a voltage between 3.15V and 3.45V on the host board.
3. The 1.8 V power supply can be optionally programmed to voltages lower than 1.8 V in modules supporting the variable power supply.

1550 nm Single-mode XFP Transceiver up to 80km link length

10GBASE-ZW/ZR Ethernet

SONET OC-192/SDH STM-64 ITU-T G.959.1 P1L1-2D2

SONET OC-192/SDH STM-64 with ITU-T G.709

**Preliminary**

## Eye Safety Mark

The XFP series single-mode transceiver is a class 1 laser product. It complies with EN 60825-1 and FDA 21 CFR 1040.10 and 1040.11. In order to meet laser safety requirements the transceiver shall be operated within the Absolute Maximum Ratings.

### Caution

**All adjustments have been done at the factory before the shipment of the devices. No maintenance and user serviceable part is required. Tampering with and modifying the performance of the device will result in voided product warranty.**

### Required Mark

**Class 1 Laser Product  
Complies with  
21 CFR 1040.10 and 1040.11**

Note : All information contained in this document is subject to change without notice.